



SWING CHECK VALVE ♦ WAFER TYPE ♦ SHORT PATTERN

ASME CLASS 150 ♦ CARBON STEEL & STAINLESS STEEL

MODELS: CV 12-CS

Body: Carbon Steel

Seat/Seal: Buna-N

CV 12-SS

Body: Stainless Steel

Seat/Seal: PTFE

SIZES: 2" ~ 24"



FEATURES

- ♦ **ROBUST DESIGN**
THIS IS A SELF-ACTING, NON-RETURN, SINGLE PLATE, WAFER TYPE SWING CHECK VALVE WHICH PROVIDES HIGH QUALITY AND RELIABILITY WITHIN A SIMPLIFIED CONSTRUCTION. AVAILABLE IN BOTH CARBON STEEL AND STAINLESS STEEL.
- ♦ **MINIMAL HEAD LOSS**
THE LOW INERTIA DISC IS DESIGNED TO OPEN AND CLOSE UNDER LOW DIFFERENTIAL PRESSURE CONDITIONS. ALSO, THE SHORT PATTERN DESIGN AND STRAIGHT FLOW PATH MINIMIZE PRESSURE DROP ACROSS THE VALVE.
- ♦ **ECONOMICAL DESIGN**
THE LOW WEIGHT AND SHORT FACE-TO-FACE DIMENSIONS PROVIDE AN ECONOMICAL, SPACE-SAVING SOLUTION. ADDITIONALLY, FLANGE GASKETS ARE TYPICALLY NOT REQUIRED DUE TO THE BUILT-IN, BODY SEAL O-RINGS.
- ♦ **RESILIENT SOFT SEATS**
SOFT SEATS (PTFE OR BUNA) COMBINED WITH A GRAVITY ASSISTED DISC HELP TO ENSURE A POSITIVE SHUTOFF WHICH CREATES A BUBBLE TIGHT SEAL THAT MEETS OR EXCEEDS API 598 LEAKAGE REQUIREMENTS.
- ♦ **VERSATILE DESIGN**
THIS VALVE CAN BE INSTALLED BETWEEN WELD NECK OR SLIP-ON TYPE COMPANION FLANGES OF DIFFERENT STANDARDS. THIS VALVE CAN NOT BE INSTALLED IN A VERTICAL PIPELINE WITH DOWNWARD FLOW.
- ♦ **FUGITIVE EMISSION DESIGN**
THE ONE-PIECE BODY DESIGN ELIMINATES POTENTIAL LEAK PATHS TO THE ENVIRONMENT SO THERE ARE NO BODY EMISSIONS.

TECHNICAL

PRESSURE/TEMPERATURE RATING ⁽¹⁾
CS - ASTM A515 GR. 70 - CLASS 150

WOG (Non-shock): 285 PSI @ 100 °F

PRESSURE/TEMPERATURE RATING ⁽¹⁾
SS - ASTM A240 GR. 316 - CLASS 150

WOG (Non-shock): 275 PSI @ 100 °F

SEAT AND BODY SEAL (O-RING) ⁽¹⁾
TEMPERATURE RANGE

PTFE: -100 ~ 400 °F
BUNA-N: -20 ~ 250 °F

1. The above listed temperatures are theoretical and may vary during actual operating conditions.

APPLICATIONS

MARKETS: OIL AND GAS PRODUCTION, GENERAL INDUSTRY, CHEMICAL, & PETROCHEMICAL

SERVICE: THIS VALVE IS INTENDED FOR LOW FLOW SERVICE THAT IS STEADY, CLEAN (NO ABRASIVES OR SOLIDS), AND NON-PULSATING. FLOW RATE MUST NOT EXCEED FOR LIQUIDS: 15 FT/SEC

PTFE PROPERTIES: GOOD FOR MOST CHEMICAL ENVIRONMENTS. OFFERS EXCELLENT TEAR, ABRASIVE, CHEMICAL, ACID, AND ALKALI RESISTANCE. NOT RECOMMENDED FOR HIGH PRESSURE STEAM OR LARGE TEMPERATURE VARIATIONS.

BUNA-N PROPERTIES: MOST WIDELY USED ELASTOMER. GOOD FOR MOST PETROLEUM OILS AND FLUIDS, SILICONE GREASES AND OILS, AND COLD WATER. EXCELLENT COMPRESSION SET, TEAR, AND ABRASION RESISTANCE. POOR WEATHER RESISTANCE AND MODERATE HEAT RESISTANCE. NOT RECOMMENDED FOR SEVERE OZONE-RESISTANT APPLICATIONS.

The above data represents common market and service applications. No representation or guarantee, expressed or implied, is given due to the numerous variations of concentrations, temperatures and flow conditions that may occur during actual service.

Distributed by
PVC FITTINGS ONLINE
a division of Commercial Industrial Supply



BILL OF MATERIALS (1)

No.	PART	CV 12-CS	CV 12-SS
1	Body	Carbon Steel A515 Gr. 70	Stainless Steel A240 Gr. 316
2	Disc	Stainless Steel A351-CF8	Stainless Steel A351 Gr. CF8M
3	Seat (2)	Buna-N	PTFE
4	Body Seal (2)	Buna-N	PTFE
5	Bolt	Stainless Steel Type 304-SS	Stainless Steel Type 304-SS
6	Eye Bolt	Chrome Plated	Chrome Plated

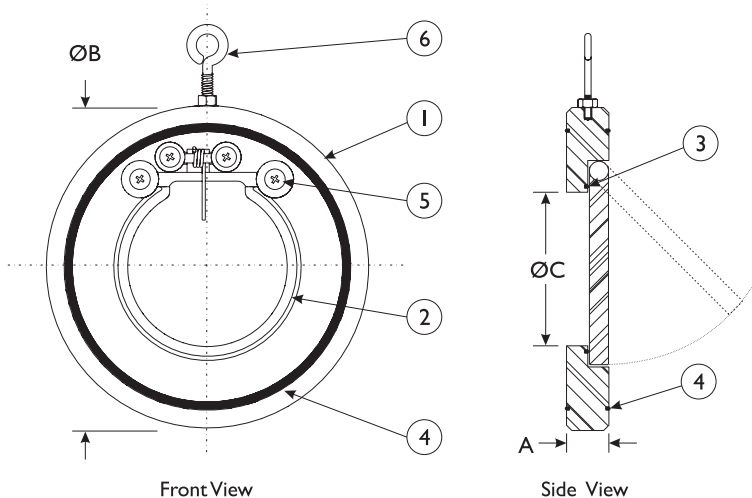

1. Bill of Materials represents standard materials. Equivalent or better materials may be substituted at the manufacturer's discretion.
2. Denotes recommended spare parts.

DIMENSIONS AND PERFORMANCE DATA (1)

SIZE	in	2	2 1/2	3	4	5	6	8	10	12	14	16	18	20	24
	mm	50	65	80	100	125	150	200	250	300	350	400	450	500	600
A DIMENSION FACE TO FACE (2)	in	0.55	0.55	0.55	0.71	0.71	0.79	0.87	1.02	1.26	1.50	1.73	1.97	2.21	2.44
	mm	14	14	14	18	18	20	22	26	32	38	44	50	56	62
ØB DIMENSION OVERALL DIAMETER	in	4.13	4.90	5.40	6.90	7.76	8.74	11.00	13.39	16.14	17.76	20.28	21.70	23.90	28.25
	mm	105	124	137	175	197	222	280	340	410	451	515	550	606	718
ØC DIMENSION INLET DIAMETER	in	1.26	1.58	2.13	2.76	3.62	4.41	6.06	7.87	9.45	10.60	12.13	14.17	15.95	19.14
	mm	32	40	54	70	92	112	154	200	240	269	308	360	405	486
ASSEMBLED WEIGHT	lb	2.5	3.5	6.0	7.0	8.5	10.0	22.0	33.5	58.0	93.5	146.5	195.0	232.0	352.0
	kg	1.1	1.6	2.7	3.2	3.9	4.5	10.0	15.2	26.3	42.4	66.5	88.5	105.1	159.5
Flow Coefficient	C _v	62	100	166	318	470	610	1250	2300	4150	4980	8225	11906	20000	27700
Cracking Pressure (3)	psi	≤ .25	≤ .25	≤ .25	≤ .25	≤ .25	≤ .25	≤ .25	≤ .25	≤ .25	≤ .25	≤ .25	≤ .25	≤ .25	≤ .25

1. Dimensions, weights, and flow coefficients are provided for reference only. When required, always request certified drawings.
2. Face to face values have a tolerance of ±0.06 in (±2.0 mm) for sizes 10" and smaller and a tolerance of ±0.12 in (±3.0 mm) for sizes 12" and larger.
3. Cracking pressure is for horizontal installations only. For vertical installations, please consult factory. Valve can not be installed in the vertical position with downward flow.

PRESSURE-TEMPERATURE RATINGS (1)

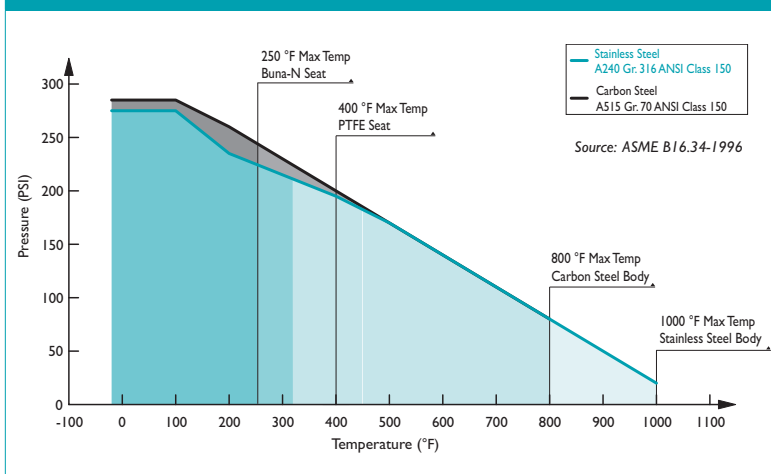

1. This chart displays the pressure-temperature ratings for the valve's body. Max temperature limits have been added for seat, body seal, and spring materials.

REFERENCED STANDARDS & CODES

CODE	DESCRIPTION
API 598 B16.5	Valve Testing
ASME B16.34	Valves - Flanged, Threaded, & Welding End
ASME 150	Flange Standard Conformity

PRESSURE/TEMPERATURE RATING

ASME CLASS 150	A240 Gr. 316	A515 Gr. 70
WOG (Non-shock)	275 PSI @ 100 °F	285 PSI @ 100 °F

SEAT/BODY SEAL TEMPERATURE RANGE (1)

SEAT	Temperature
PTFE	-100 ~ 400 °F
Buna-N	-20 ~ 250 °F

1. The listed pressure and temperature ratings for the valve's body, seat, and body seal are theoretical and may vary during actual operating conditions.

ORDERING CODE

Model Number	Description
CV 12-CS	Carbon Steel Body, Buna-N Seat
CV 12-SS	Stainless Steel Body, PTFE Seat

Additional Design & Technical Notes:

Short pattern check valves feature a reduced port and eccentric opening which allow the disc to open into the connecting pipe. However, given the short face-to-face, the disc will not fully open due to interference with the connecting pipe. Although this conforms to API specifications, this may be unsuitable for certain types applications. Consult factory for more specific application information.