



Two Piece Full Bore Economical Ball Valves

TWO PIECE ECONOFLO SERIES

Model : T80SS

Pressure:

1000 MAWP/WOG / 150 SWP

Materials:

316 Stainless Steel - Standard
Carbon Steel - Optional

Temperature Range:

-20 °F to 450 °F
-28.9 °C to 232 °C

Size Range:

1/4" - 4"
Threaded Ends

Valves are also available
with ISO-5211 actuator
mounting pad, see
model T23.

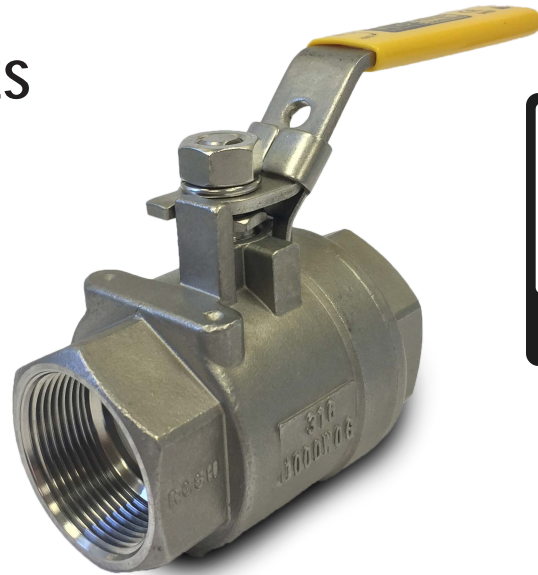

DESIGN FEATURES

- **Full Port** - Straight through flow minimizes pressure drop and prolongs valve life
- Internal Entry Blow-out Proof Stem
- **Locking Handle** - Standard on all valves meets OSHA 1910.147
- **Adjustable** V-Ring Stem Packing
- **Bubble Tight** - Zero Leakage
- **Investment casting** improves dimensional control and reduces porosity
- **Two Piece Econoflo Series** is an ideal general purpose stainless steel valve, meeting plant - wide applications.

T80SS Full Port Ball Valve Design & Technical Data

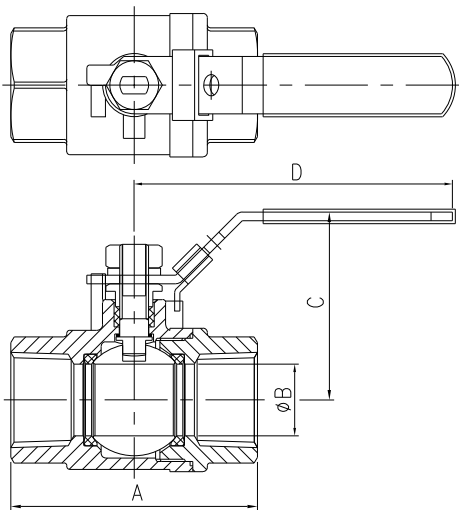

DIMENSIONS AND WEIGHTS:

SIZE	A		B		C		D		Cv	Torque in-lb	Weight lbs
	in	mm	in	mm	in	mm	in	mm			
1/4"	1.97	50	0.43	11	2.09	53	3.70	94	10	50	0.5
3/8"	2.05	52	0.43	11	2.09	53	3.70	94	12	54	0.5
1/2"	2.32	59	0.49	12.5	2.09	53	3.70	94	38	59	0.58
3/4"	2.72	69	0.79	20	2.22	56.5	3.70	94	66	85	0.91
1"	3.15	80	0.98	25	2.58	65.5	4.37	111	105	150	1.51
1 1/4"	3.62	92	1.26	32	2.80	71	4.37	111	190	234	2.33
1 1/2"	4.13	105	1.50	38	3.15	80	5.37	136.5	275	344	3.51
2"	4.84	123	1.97	50	3.52	89.5	5.37	136.5	480	476	5.73
2-1/2"	5.91	150	2.56	65	5.06	128.5	9.57	243	797	875	11.75
3"	6.69	170	2.99	76	5.49	139.5	9.57	243	1210	1330	11.72
4"	8.86	225	3.94	100	6.50	165	10.79	274	2000	c/f	c/f

Dimensions are for estimating purpose only. Please consult factory for exact dimensions.

BILL OF MATERIALS:

Item	Name	T80SS	T80CS	Qty
1	Body	ASTM A351 CF8M	ASTM A216 WCB	1
2	End Cap	ASTM A351 CF8M	ASTM A216 WCB	1
3	Ball	ASTM A276 Type 316	ASTM A276 Type 304	1
4	Seats #	PTFE	PTFE	2
5	Gasket #	PTFE	PTFE	1
6	Stem	ASTM A276 Type 316	ASTM A276 Type 304	1
7	Thrust Washer#	PTFE	PTFE	1
8	Stem Packings #	PTFE	PTFE	2
9	Gland Nut	SS304	SS304	1
10	Handle	SS304	Zinc Plated Steel	1
11	Locking Device	SS304	Zinc Plated Steel	1
12	Lever Sleeve	PVC	PVC	1
13	Spring Washer	SS304	SS304	1
14	Nut	SS304	SS304	1

Parts included in repair kits

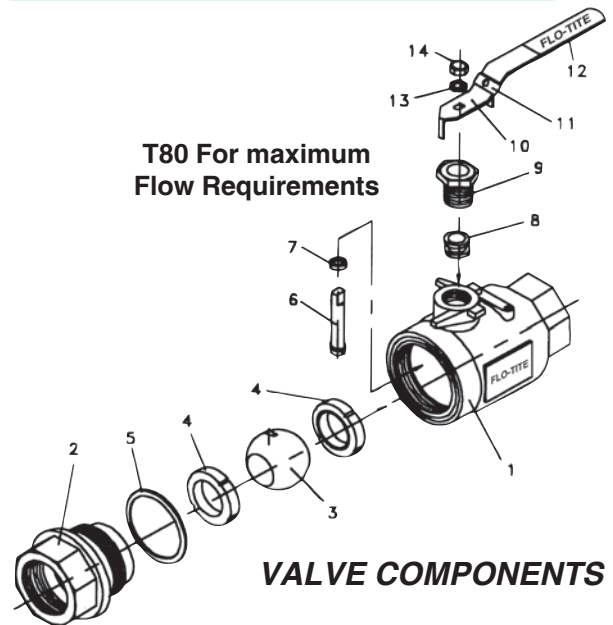

VALVE COMPONENTS

PRESSURE AND TEMPERATURE DATA

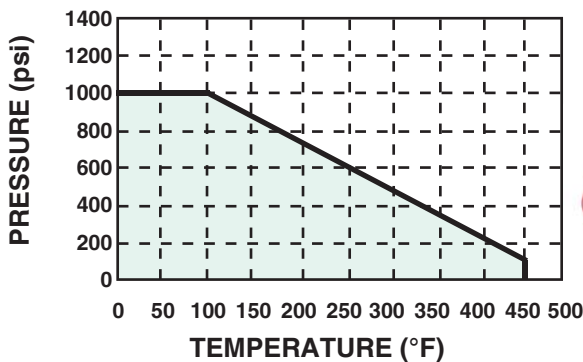

PRESSURE RATING: 1000 MAWP/WOG

ATTENTION
MAWP/WOG is a do not exceed pressure at normal ambient NPT & Weld End Models

TESTING

All valves are 100% air tested underwater at 100 psi in Open and Close positions.

T80SS Conforms to:
Federal Specification WW-V-35B
Type II, Class C Style 3

Pipe Thread in accordance with ANSI B1.20.1

Note: Our T80 Series Valves are not designed to be actuated. please see our T23 Fusion Series Tech Bulletin Page 14.